

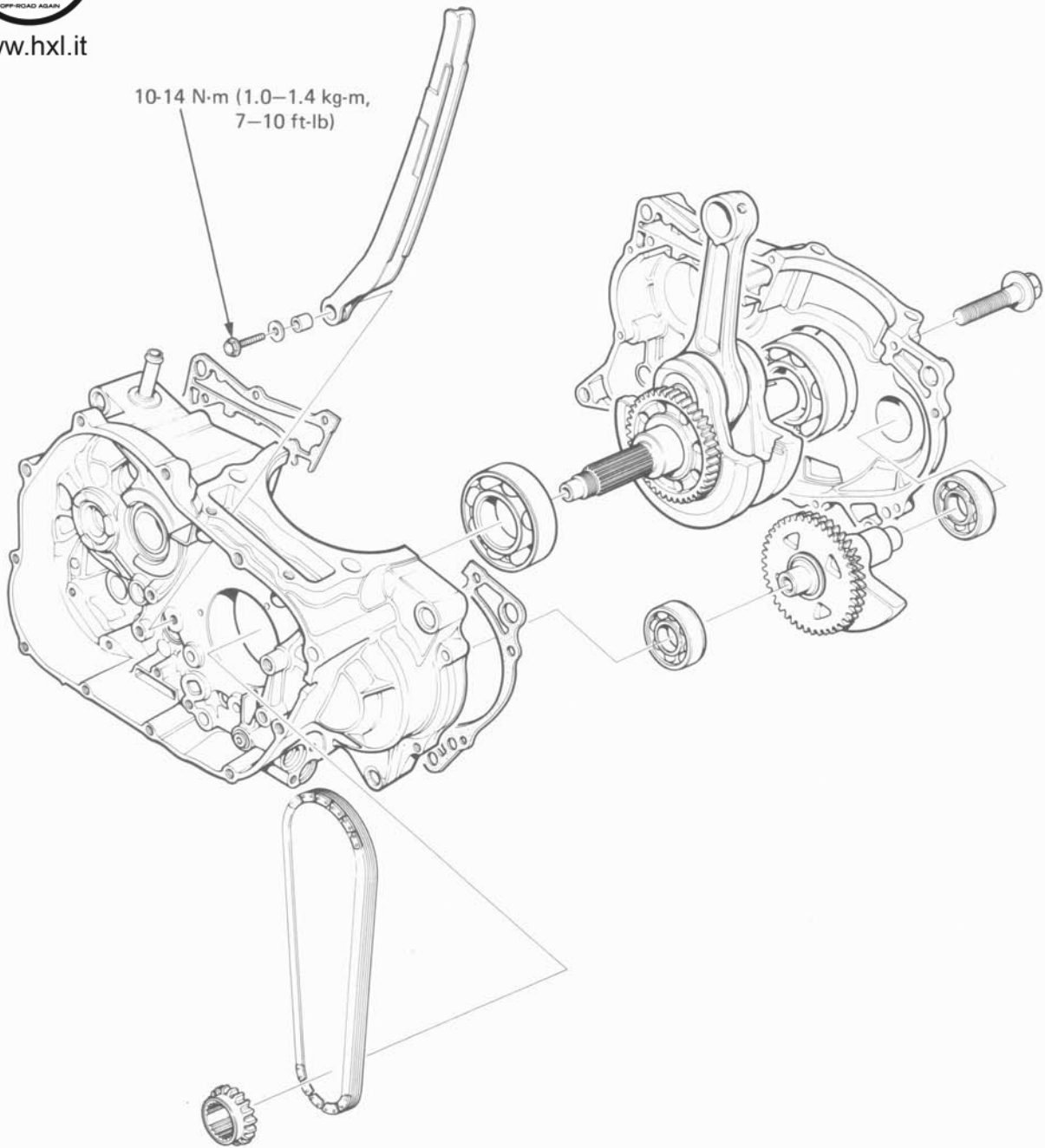

www.hxl.it





SERVICE INFORMATION	10- 1
TROUBLESHOOTING	10- 2
CRANKCASE SEPARATION	10- 3
BALANCER REMOVAL	10- 4
CRANKSHAFT REMOVAL	10- 7
CRANKSHAFT AND BALANCER INSTALLATION	10-10
CRANKCASE ASSEMBLY	10-11

## SERVICE INFORMATION

### GENERAL

- The crankcase must be separated to repair the crankshaft, connecting rod, kick starter, transmission and balancer.
- Remove the following parts before separating the crankcase.

ENGINE REMOVAL	Section 5
CYLINDER HEAD	Section 6
CLUTCH/OIL PUMP/KICKSTARTER	Section 7
CLUTCH/OIL PUMP	Section 8
AC GENERATOR	Section 9

- To service the crankshaft or balancer, it is necessary to separate the crankcase.

### SPECIFICATIONS

ITEM	STANDARD	SERVICE LIMIT	
Crankshaft	Connecting rod big end side clearance	0.050–0.650 mm (0.0020–0.0256 in)	0.80 mm (0.031 in)
	Connecting rod big end radial clearance	0.006–0.018 mm (0.0002–0.0007 in)	0.05 mm (0.002 in)
	Connecting rod small end I.D.	24.020–24.041 mm (0.9457–0.9465 in)	24.07 mm (0.948 in)
	Crankshaft runout	—————	0.1 mm (0.004 in)
Balancer	Shaft O.D. A	16.977–16.995 mm (0.6684–0.6691 in)	16.95 mm (0.667 in)
Crankshaft bearing play	Radial	—————	0.05 mm (0.002 in)
	Axial	—————	0.10 mm (0.004 in)

### COMMON TOOLS (for crankshaft bearing installation)

Driver	07749–0010000	Attachment, 37 x 40 mm	07746–0010200
Attachment, 72 x 75 mm	07746–0010600	Pilot, 17 mm	07746–0020300
Pilot, 40 mm	07746–0040900	Pilot, 35 mm	07746–0040800

### SPECIAL TOOL

Crank assembly kit	07931–KF00000	— Assembly collar	07931–KF00100
		— Thread adapter	07931–KF00200
		— Shaft puller	07931–ME00000
Bearing remover, 17 mm	07936–3710300	(Balancer bearing)	
Oil seal driver	07947–6930100	(Crankshaft bearing)	
Remover weight	07936–3710200		
Remover handle	07936–3710100		



## TORQUE VALUES

Right crankcase	8–12 N·m (0.8–1.2 kg-m, 6–9 ft-lb)
Left crankcase	8–12 N·m (0.8–1.2 kg-m, 6–9 ft-lb)
Cam chain tensioner	10–14 N·m (1.0–1.4 kg-m, 7–10 ft-lb)

## TROUBLESHOOTING

### Excessive Noise

1. Crankshaft
  - Worn connecting rod bearing
  - Bent connecting rod
  - Worn crankshaft bearing
2. Balancer
  - Improper installation



## CRANKCASE SEPARATION

Remove the cam chain and cam chain drive gear.  
Remove the cam chain tensioner, collar and washer.

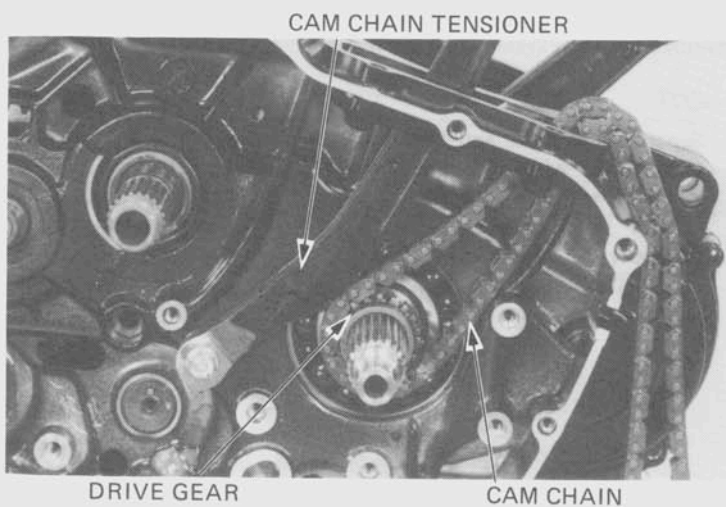

Remove the right crankcase bolts.

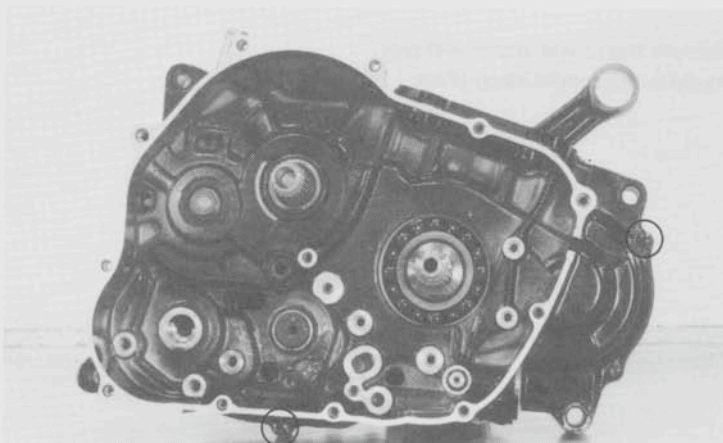

Remove the left crankcase bolts.

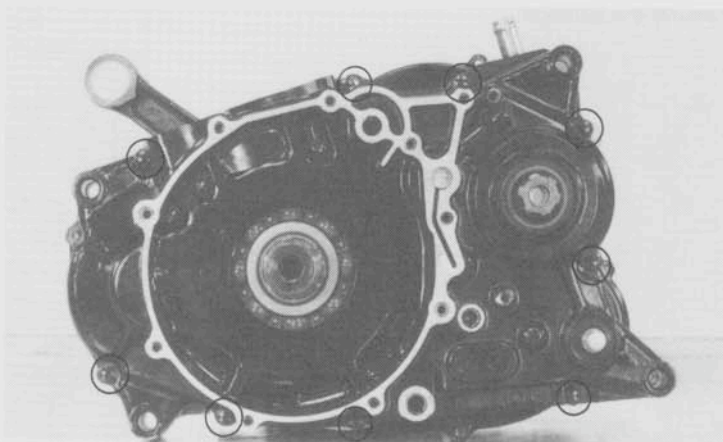



Remove the right crankcase from the left crankcase.

**NOTE**

Separate the right and left crankcases from each other while tapping them at several locations with a soft hammer.

**CAUTION**

*Do not pry the crankcases apart with a screwdriver.*

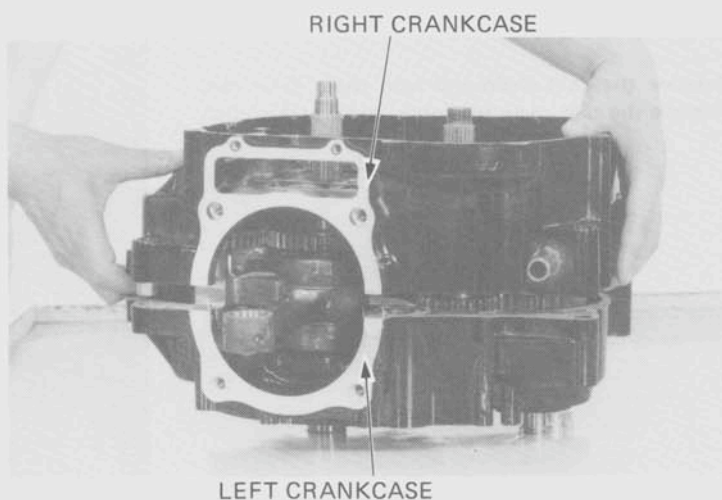

## BALANCER REMOVAL

Remove the gasket and dowel pins.  
Remove the transmission (Page 11-3).

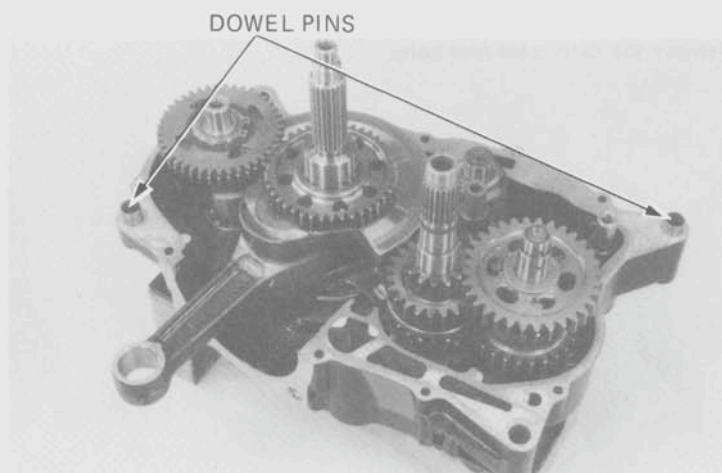

Remove the balancer.

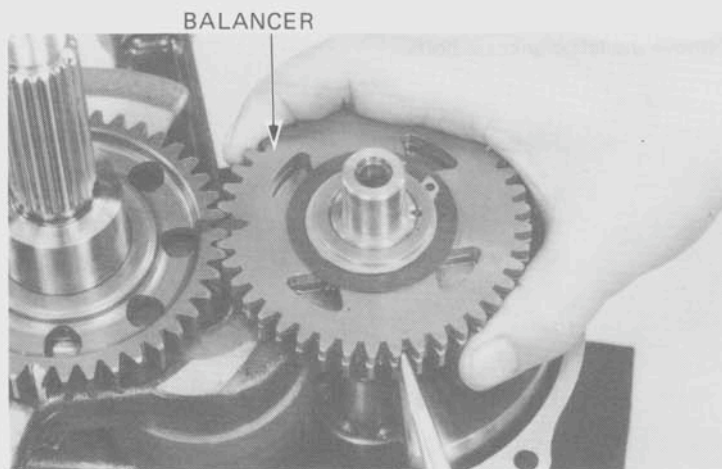



**BALANCER DISASSEMBLY**

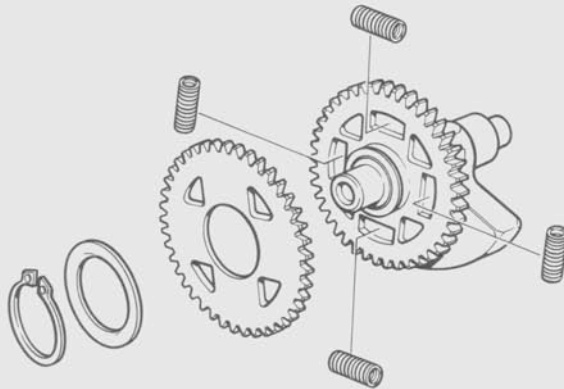

Remove the snap ring, thrust washer and outer driven gear.

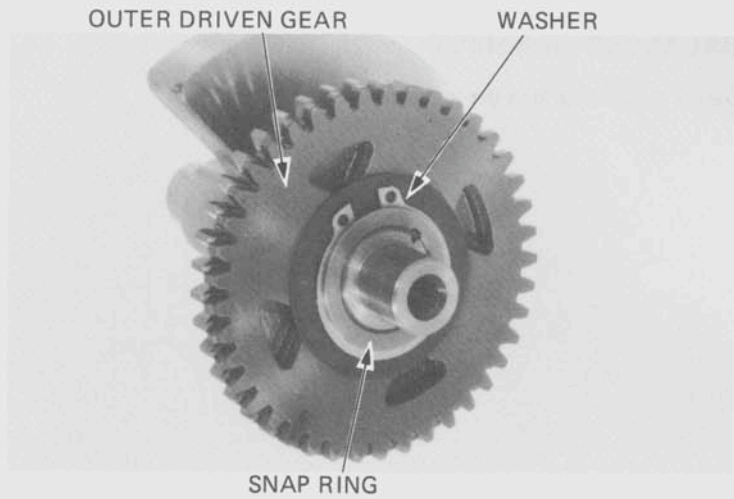

Remove the springs.

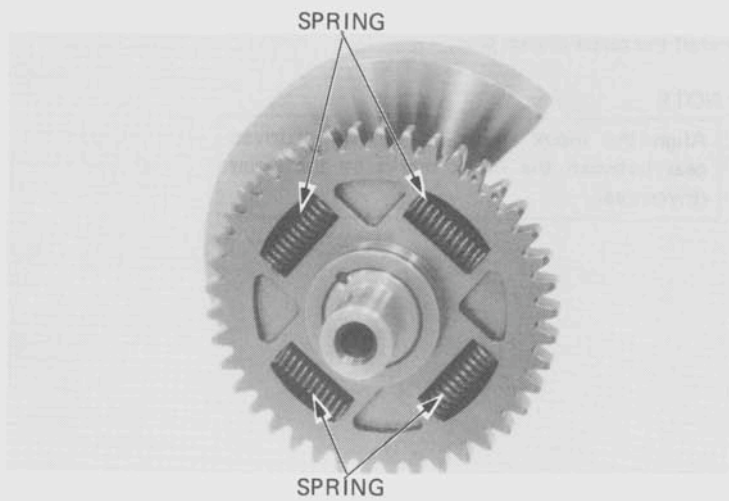



### BALANCER INSPECTION

Measure the balancer O.D. on each side.  
**SERVICE LIMIT: 16.95 mm (0.667 in)**

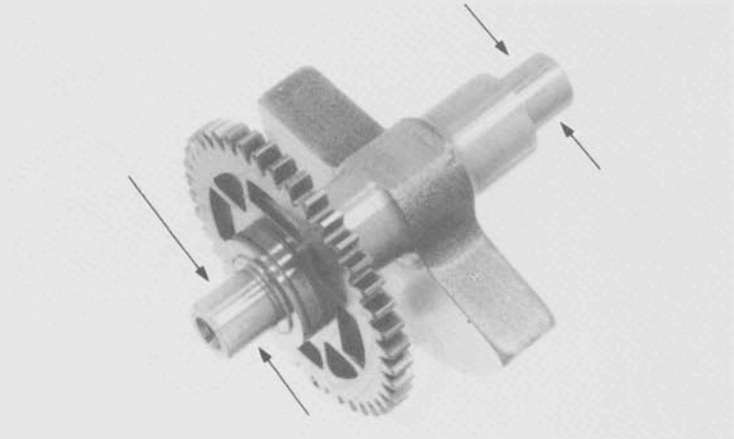

### BALANCER ASSEMBLY

Install the springs into the inner driven gear.



Install the outer driven gear.

#### NOTE

Align the index mark on the inner driven gear between the index marks on the outer driven gear.

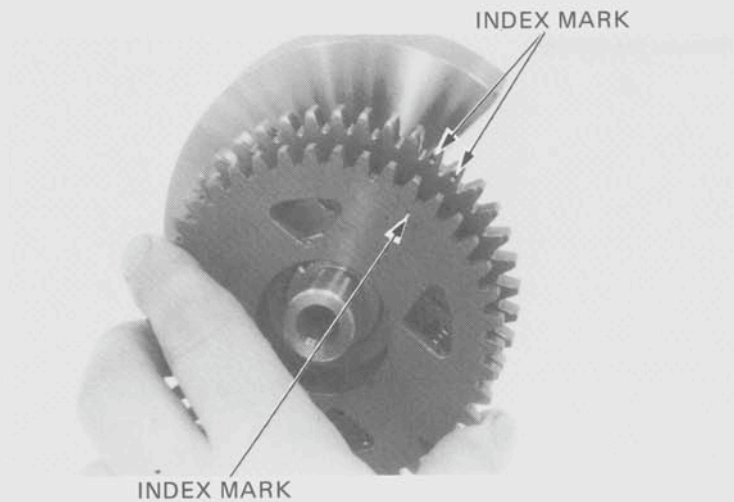



## CRANKSHAFT REMOVAL

Remove the transmission and balancer.  
Remove the crank shaft from the left crankcase by using a hydraulic press, as shown.

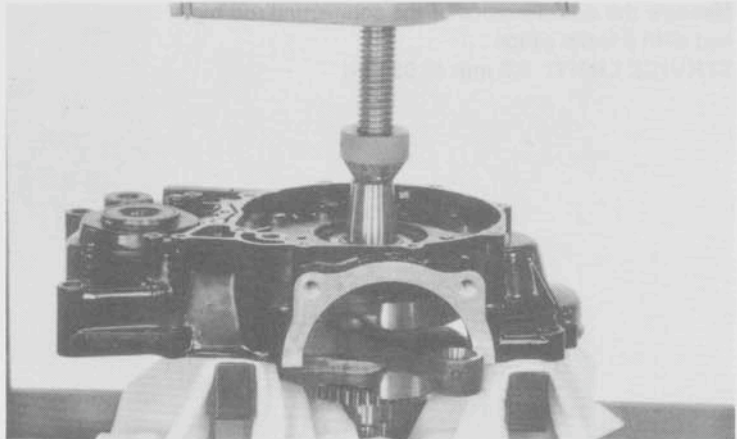

Remove the left crankcase bearing using a bearing puller.

If it is removed with the crankshaft. Discard the bearing.

### CAUTION

*Always replace the left bearing with a new one if it is removed with the crankshaft.*

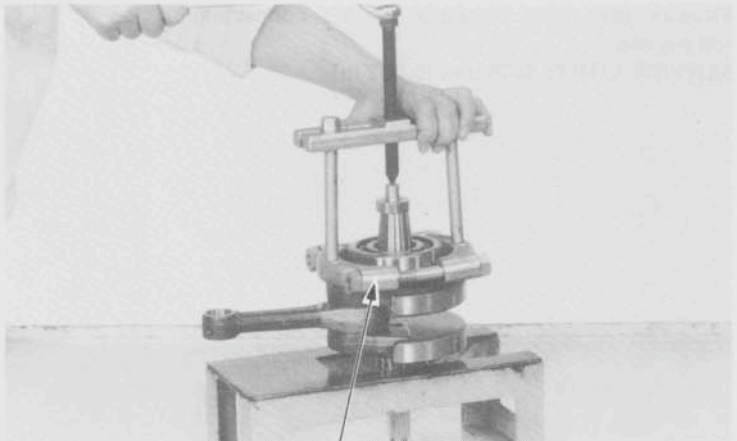

BEARING PULLER

## CRANKSHAFT INSPECTION

Place the crankshaft in a truing fixture and place a 2.5 mm shim under the left block.  
Measure the runout using a dial indicator.

### NOTE

Actual runout is 1/2 of total indicator reading.

**SERVICE LIMIT: 0.1 mm (0.004 in)**

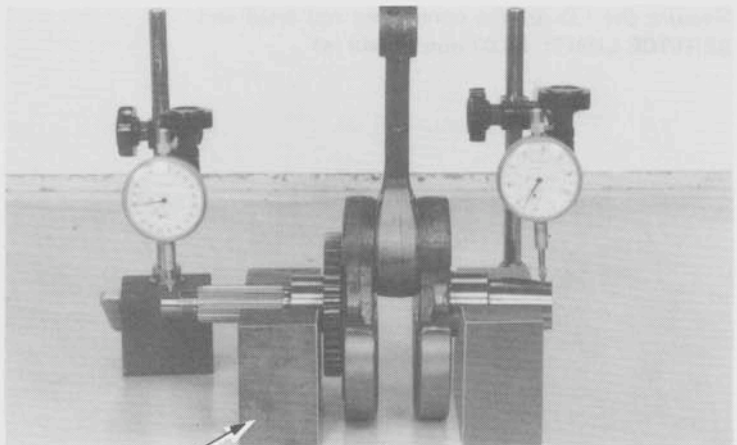

SHIM





Measure the side clearance of the connecting rod big end with a feeler gauge.

**SERVICE LIMIT: 0.8 mm (0.031 in)**

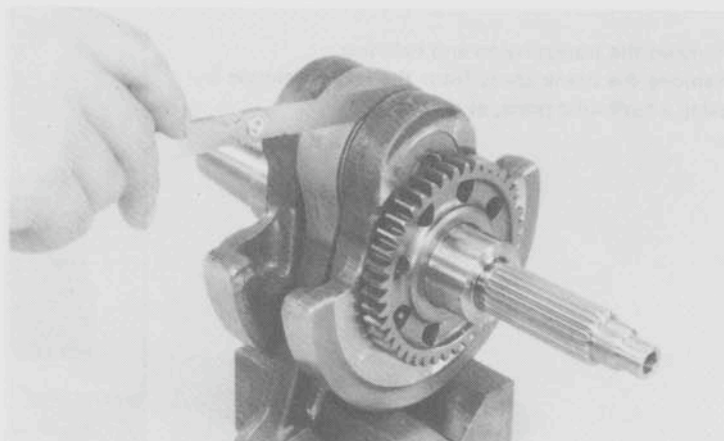

Measure the radial clearance of the connecting rod big end.

**SERVICE LIMIT: 0.05 mm (0.002 in)**

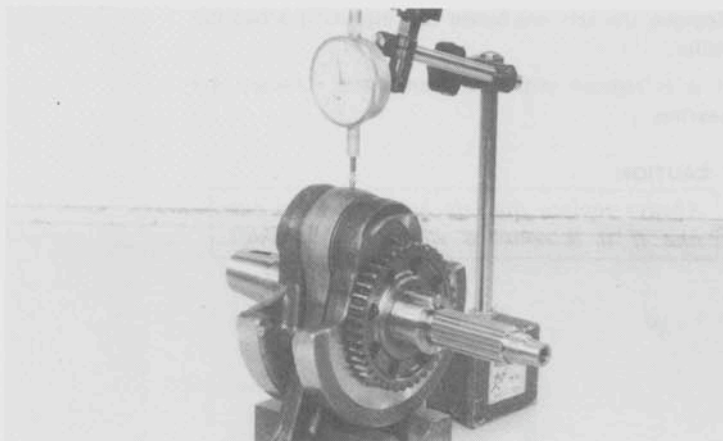

Measure the I.D. of the connecting rod small end.

**SERVICE LIMIT: 24.07 mm (0.948 in)**

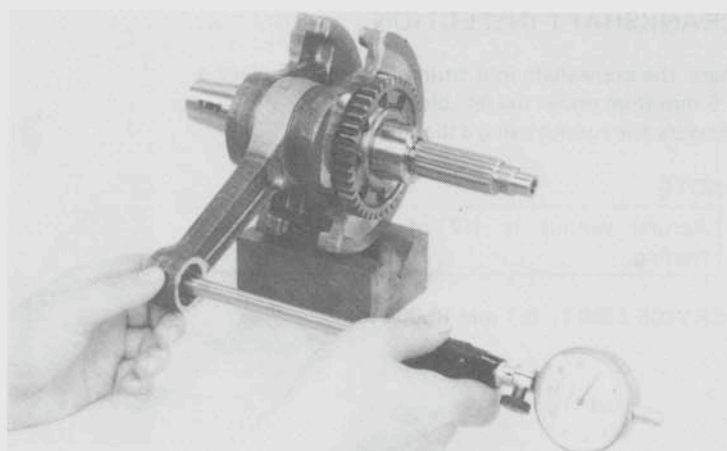



Spin the crankshaft bearings by hand and check for play.

A bearing must be replaced if it is noisy or has excessive play.

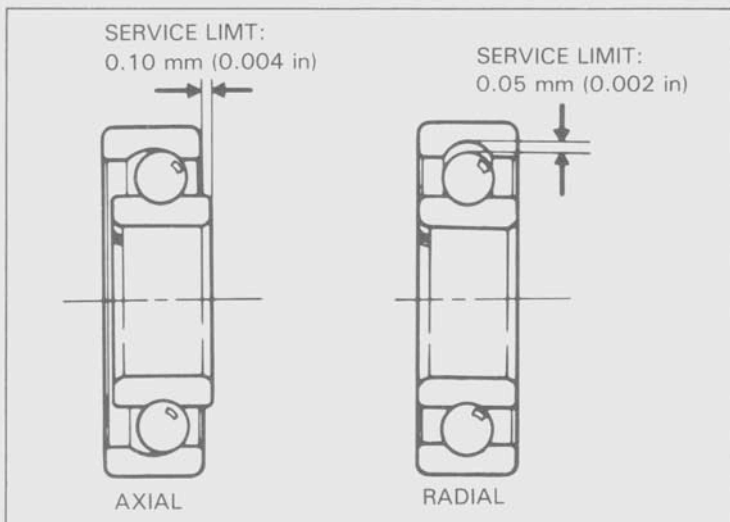

**BEARING REPLACEMENT**

Remove the crankshaft bearing from the right crankcase.

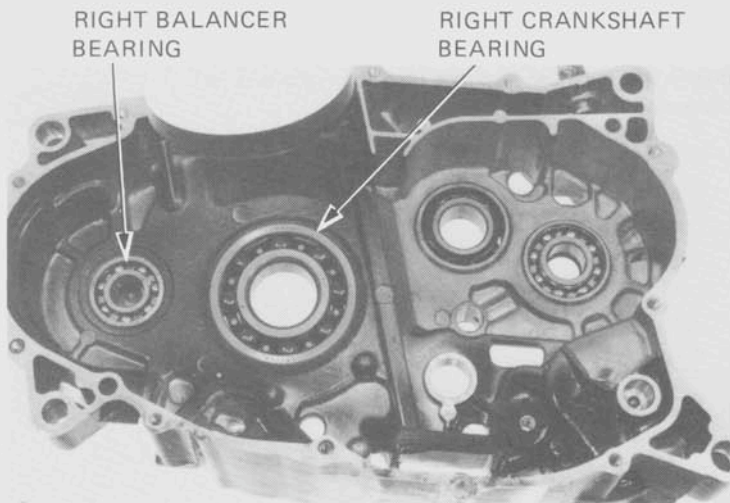

Remove the left crankshaft bearing if it is left on the crankcase.

Remove the right and left balancer bearing with the special tool.

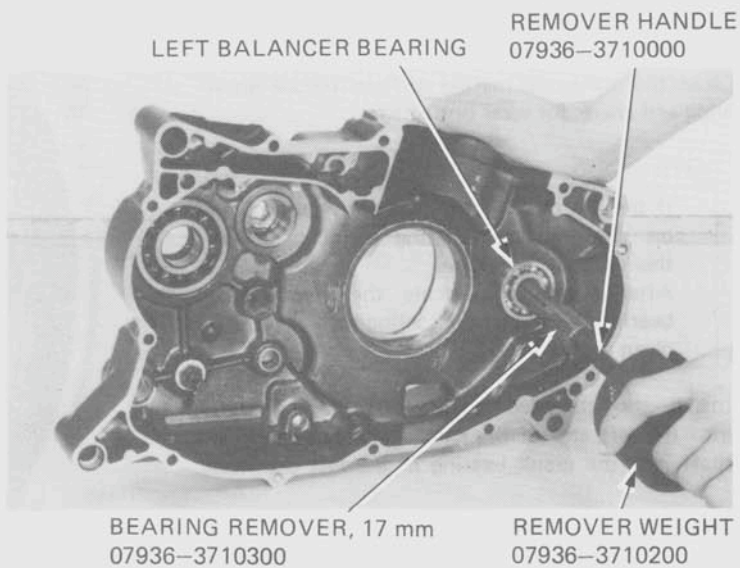

## CRANKSHAFT AND BALANCER INSTALLATION

Install the new right crankshaft bearing and bearing plate. Use the 35 mm pilot.

Install the new left crankshaft bearing into the right crankcase. Use the 40 mm pilot.

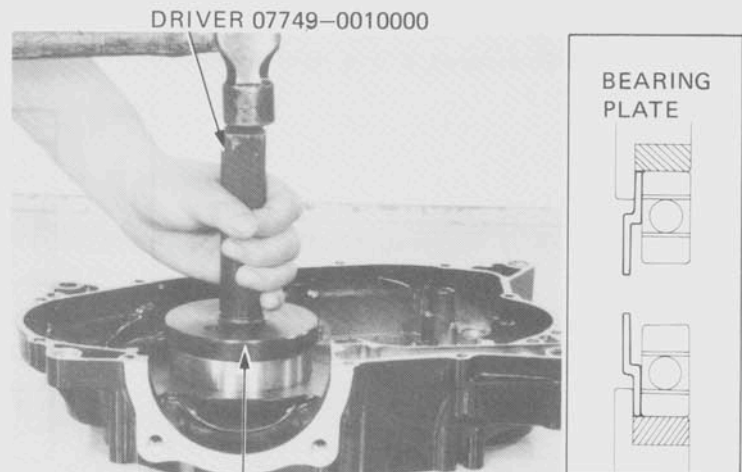

ATTACHMENT, 72 x 75 mm 07746-0010600  
PILOT, 35 mm (R. Bearing) 07746-0040800  
PILOT, 40 mm (L. Bearing) 07746-0040900

Install the balancer bearings into the right and left crankcases.



ATTACHMENT, 37 x 40 mm 07746-0010200  
PILOT, 17 mm 07446-0020300

Clean the crankcase mating surfaces before assembling and check for wear or damage.

### NOTE

- If there is minor roughness or irregularities on the crankcase mating surfaces, dress them with an oil stone.
- After cleaning, lubricate the crankshaft bearings and other contacting surfaces with clean engine oil.

Install the threaded adapter, 07931-KF00200, into the left end of the crankshaft. Then push the shaft into the crank bearing in the left crankcase.

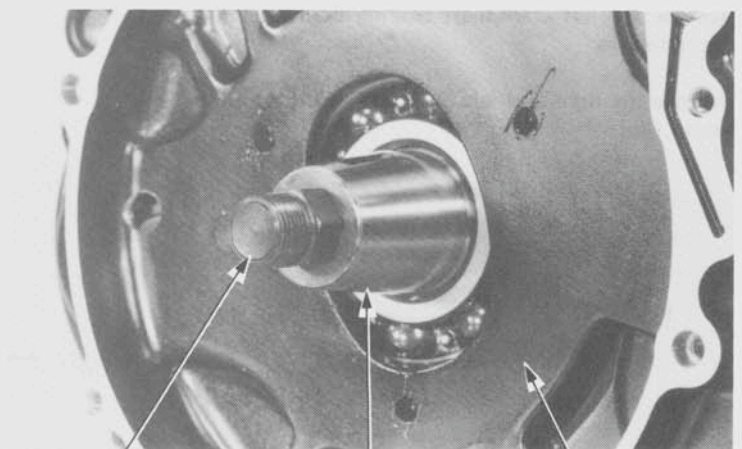

THREADED ADAPTER 07931-KF00200    CRANKSHAFT    LEFT CRANKCASE



Place the small O.D. end of the assembly collar, 07931-KF00100, over the left crankshaft end and against the bearing inner race.

Attach a shaft puller, 07931-ME40000, to the threaded adapter. Screw the puller shaft's nut down until it fits into the recess in the assembly collar.

Hold the puller with a 17 mm box wrench, and turn the nut with a 27 mm wrench to pull the crankshaft completely into the left bearing.

**NOTE**

Be sure the connecting rod stays aligned with the cylinder opening in the case.

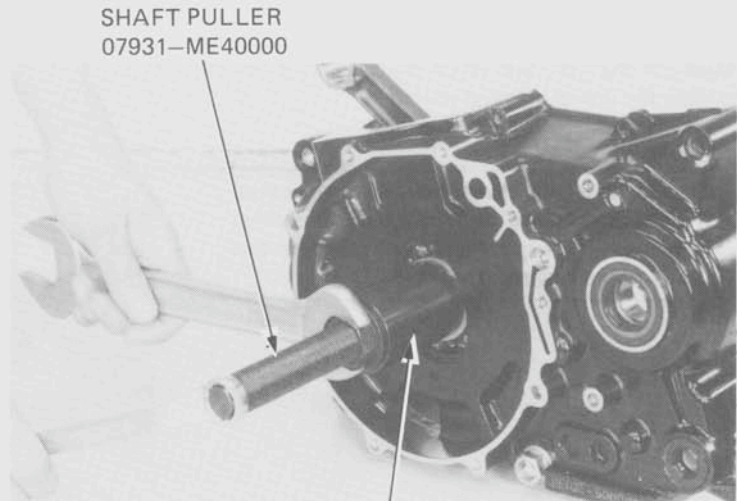

ASSEMBLY COLLAR  
07931-KF00100

Install the balancer by aligning the punch marks on the gears.

Rotate the crankshaft to make sure that balancer does not interfere with the crankshaft.

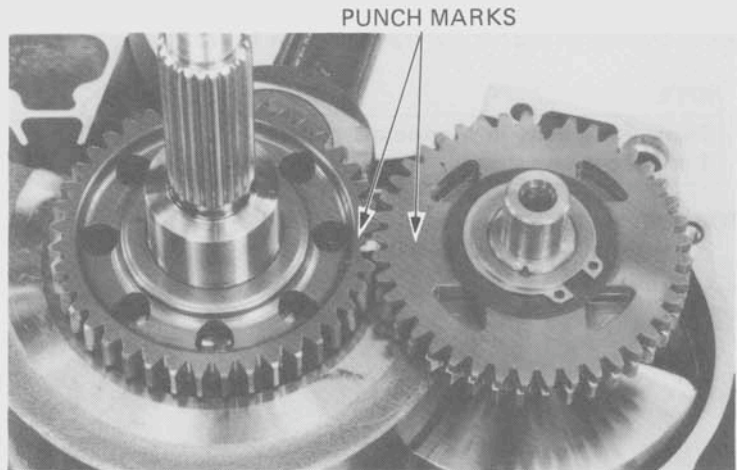

**CRANKCASE ASSEMBLY**

Install the transmission, crankshaft and balancer. Install the two dowel pins and new gasket.

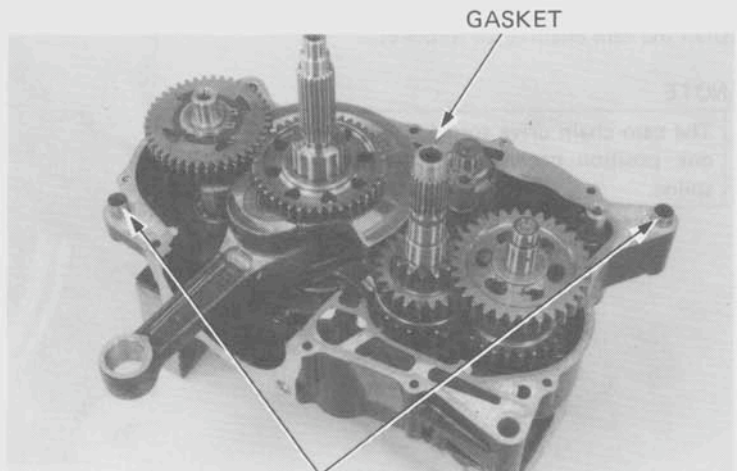



Assemble the right and left crankcase being careful to align the dowel pins and shafts.

**CAUTION**

*Don't force the crankcase halves together; if there is excessive force required, something is wrong. Remove the right crankcase and check for misaligned parts.*

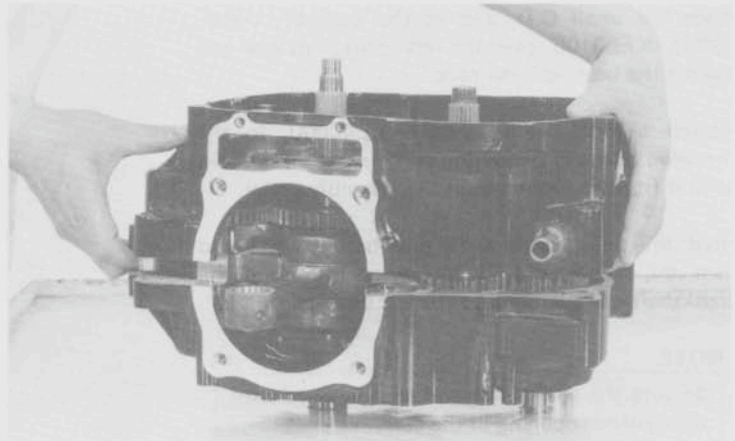

Install and tighten the left and right crankcase bolts.

**NOTE**

Tighten the bolts in a crisscross pattern in 2 or 3 progressive steps.

**TORQUE:** 8–12 N·m  
(0.8–1.2 kg·m, 6–9 ft·lb)

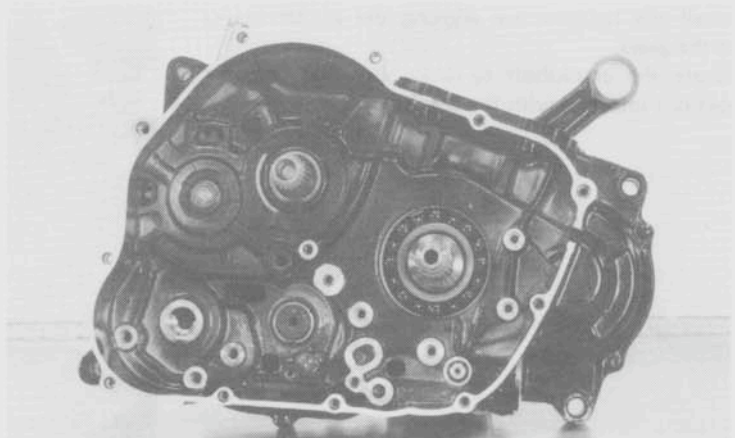

Install the cam chain drive sprocket.

**NOTE**

The cam chain drive sprocket will only go on one position because of extra-wide aligning spline.

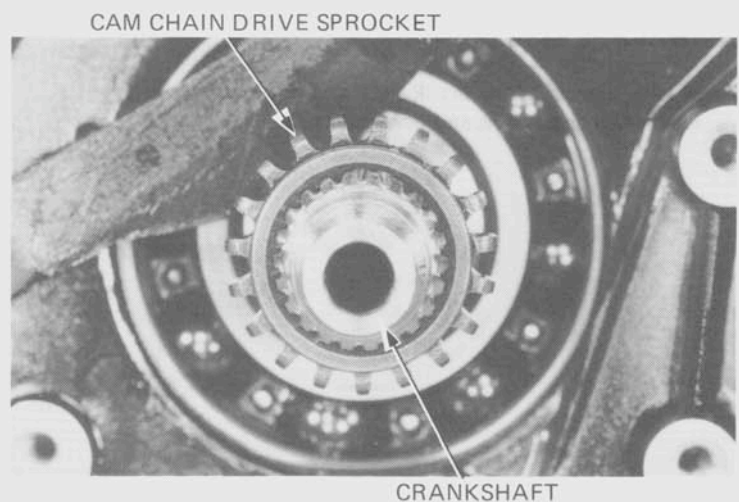



Install the cam chain.

Install the cam chain tensioner with the washer, collar and bolt.

**TORQUE: 10–14 N·m (1.0–1.4 kg·m, 7–10 ft·lb)**

Install the cam chain drive gear and cam chain.

Install the AC generator (Section 9).

Install the clutch/oil pump (Section 8).

Install the kickstarter assembly (Section

Install the cylinder/piston (Section 7).

Install the cylinder head (Section 6).

Install the engine into the frame.

CAM CHAIN TENSIONER

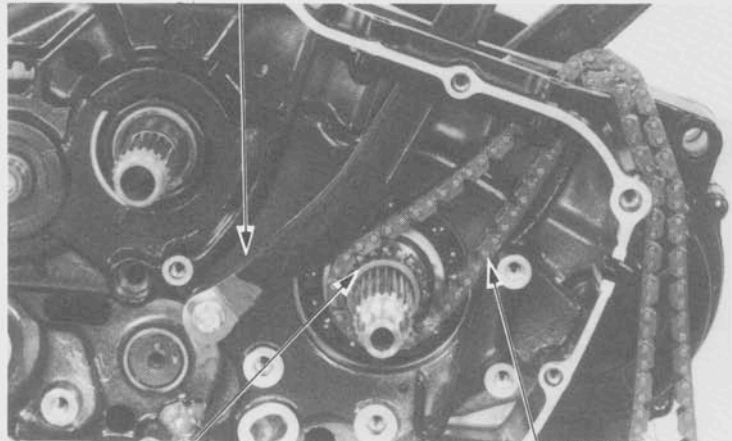

DRIVE GEAR

CAM CHAIN